

# Double Hit Combo

## OPERATOR'S MANUAL

### TABLE OF CONTENTS:

1. Introduction and Safety
2. Technical Data
3. Installation
4. How to Play
5. Technical Info
6. Motherboard Connections
7. Setup Mode
8. Credit Settings
9. Pinout Information and Diagrams
10. All Available Settings
11. Maintenance
12. Troubleshooting
13. Warranty and Service



**USER MUST FOLLOW ALL GUIDELINES INCLUDED IN THIS DOCUMENT  
FOR SAFE AND LONG-LASTING MACHINE USAGE.**

# 1. Introduction and Safety

Welcome to the Double Hit Combo, an innovative arcade amusement machine designed to measure the force of punches and kicks. It allows players to choose between two games types: boxer and kicker. This machine is specifically created for entertainment purposes in amusement environments.

## OPERATING INSTRUCTIONS:

- Please carefully read the operating instructions before using the device or performing maintenance for the first time. The warranty does not cover damages resulting from improper use if the instructions have not been read prior to operation.

## ATTENTION:

- Ensure the device is unplugged before you perform any maintenance.
- Only authorized personnel are permitted to conduct maintenance or repairs on the machine.
- Always use original spare parts for maintenance and repairs.
- The device is designed for use with 120V/60Hz power sources.
- Never disconnect any plug or connector while the power is on.
- Ensure both the plug and the socket are properly grounded.
- Protect the main cable from damage and avoid exposure to oil and acids.
- Do not place the machine near sources of steam or flammable liquids.
- Always install the machine on a clean and smooth surface.

## SAFETY USAGE INSTRUCTIONS:

- The player must stand directly in front of the machine before pressing the START button.
- Upon pressing START BOXER or START KICKER, wait in front of the machine until the bag is released.
- Once the bag is released, the player should make a fist with the thumb on the outside of their pointing and middle fingers for boxer.
- After the punch or kick, your score will be displayed on the front panel.
- Repeat these instructions for each game.

## WARNINGS WHEN OPERATING THE BOXER:

- Always target the central part of the inflated punchball.
- Avoid punching the upper part of the punchball.
- Do not punch an uninflated punchball.
- Only use your fist for punching the punchball.
- Kicking the punch ball or the machine, side pushing, running, and head butting are strictly prohibited.

# 2. Technical Data

## INSTALLED DIMENSIONS:

<b>Height:</b>	84 in / 214 cm
<b>Width:</b>	33 in / 84 cm
<b>Length:</b>	48 in / 122 cm
<b>Weight:</b>	375 lb / 170 kg
<b>Power supply:</b>	110-120 V
<b>Power consumption:</b>	90 W

## SHIPPING WITH PALLET:

87 in / 221 cm
40 in / 102 cm
48 in / 122 cm
415 lb / 188 kg

### 3. Installation

The Double Hit Combo should be installed vertically, ensuring the base is perfectly leveled. After connecting the machine to a power outlet, it will be ready for use.

#### CLEARANCE REQUIREMENTS:

Ensure there is at least 5 feet of clearance on all sides and in front of the machine. This precaution helps prevent players from hitting any nearby objects after punching or kicking the bag.

It is the installer's responsibility to define and maintain safe clearance around the machine.

### 4. How to Play

#### STEP-BY-STEP GUIDE:

1. Insert Payment: Insert coins, bills, or payment card into the respective coin, bill, or card reader.
2. Start Game: Press the START button to begin.
3. Prepare for Punch or kick: Await the release of the punchball or kicker ball.
4. Deliver Punch or kick: Strike the punchball firmly with your fist or kick the ball.
5. View Score: After your punch or kick, your score will appear on the score display.
6. Score Comparison: Compare your score with the highest score displayed.
7. Repeat Play: To try again, follow these steps starting from insertion of payment.

#### KEY COMPONENTS ON THE MACHINE:



## 5. Technical Info

### PUNCHBALL MECHANISM SCHEME

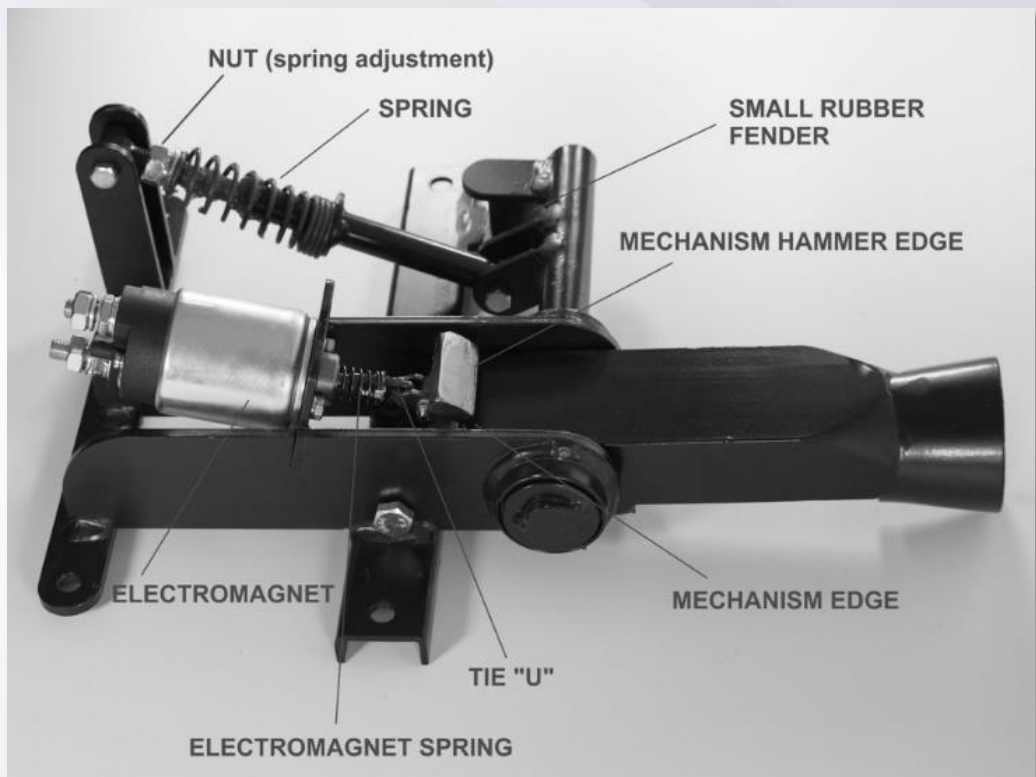

# 6. Motherboard Connections

**SETUP 1-4**  
Credits and impulses for coin acceptor

**SETUP 5-8**  
Credits and impulses for bill acceptor

**SETUP 9**  
Credits and impulses for NAYAX

**SETUP 10**  
Update software via WIFI

**SETUP 11**  
Update sounds via WIFI

**SETUP 12**  
Time of the presentation repeating

**SETUP 13**  
Restart record to the standard value (600)

**SETUP 14**  
Boxer strenght profile  
Standard: 100

**SETUP 15**  
Kicker strenght profile  
Standard: 100

**SETUP 16**  
Credit counter

**SETUP 17**  
Test Credits

**SETUP 18**  
Reset to the basic parameters

**SETUP 19**  
Language version

**SETUP 20**  
Free Play  
1 = on 0 = off

**SETUP 21**  
Ticket Record

**SETUP 22**  
Ticket Credit

**SETUP 23**  
Ticket credit score 100

**SETUP 29**  
Kids Play 1-9

**SETUP 30**  
Pulse lenght for coin and bill acceptor.  
Standard 100



Setting the amount of impulses on mechanical and electronic counter.

Setting of the quantity of credits per each thrown coin.

Only available with Android mobile phones / no iOS

To Update the device, you must create hotspot on your phone with internet connection.

**NETWORK NAME:** ProGames  
**PASSWORD:** ProGames2023Hit

0 = English	6 = Czech Republic
1 = Polish	7 = Ukraine
2 = Russian	8 = French
3 = German	9 = Greece
4 = Spanish	10 = Hungary
5 = Italian	

Number of tickets for breaking the record

Number of tickets for inserting credits

Number of tickets for each 100 points

10% - 90% more points

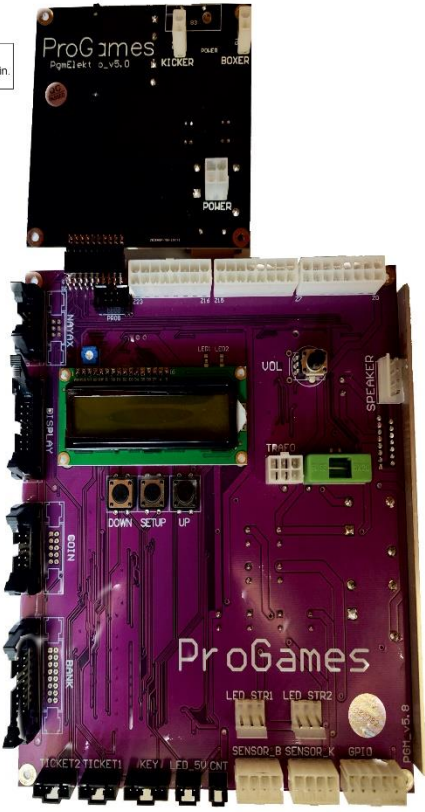

**DOUBLE HIT**

## 7. Setup Mode

### 1. START SETUP MODE:

- Press the SETUP button on the Motherboard; listen for a bell sound as confirmation that you've entered setup mode.

### 2. NAVIGATING SETUP MODE:

- Use the UP and DOWN button to move between channels (1 to 30).
- To change a value, press the SETUP button.

### 3. CONFIRMING CHANGES:

- After changes, press the SETUP button to confirm each change; a confirmation sound will play.
- To save the changes, turn OFF the machine.

## 8. Credit Settings

Adjust the settings for accepting payments through various channels using the control panel. Configurations can significantly alter how credits are accrued, affecting gameplay and user interaction.

### CREDIT SETTINGS AND EXAMPLES:

- **Channel 1 to 4:** Adjust settings for coins.
- **Channel 5 to 8:** Adjust settings for bills.
- **Channel 9:** Nayax. Adjust settings for card readers.

### DISPLAY OF VALUES:

- Example for channel 1 (Coin Acceptor):  
Display reads ".25" per quarter inserted; 4 quarters yield 1 credit.
- Example for channel 5 (Bill Acceptor):  
Inserting a \$1 note, Display reads "1", and "1", resulting in 1 credit.



## 9. Pinout Information and Diagrams

### COIN MECHANISM / CARD READER

DOUBLE HIT COIN SETTINGS = CHANNEL 1 TO 4

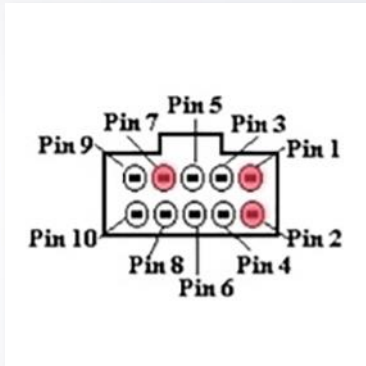

COIN MECHANISM PINOUT

Nº PIN	MEANING
1	NEGATIVE
2	+ 12 VDC
3	-
4	-
5	INHIBIT SORTER
6	INHIBIT RMS
7	CH1
8	CH2
9	CH3
10	CH4

PULSE DURATION = 100 MS  
PULSE WIDTH = 100 MS

# BILL ACCEPTOR / CARD READER

## DOUBLE HIT COMBO BILL ACCEPTOR SETTINGS = CHANNELS 5 TO 8

Factory ready: Pyramid bill acceptor

Model: Apex 7400-U11 USA 12V

SWITCH
1 ON
2 ON
3 ON
4 ON
5 ON
6 ON
7 OFF
8 OFF



**PYRAMID SWITCH CONFIGURATION**

Pin	18-Pin Connector Function (wire color)
1	\$1 Low-level credit line output (Brown)
2	-INT line for Mars 600-baud mode (Orange)
3	Serial~Pulse or (Yellow)
4	DC Power Ground (Black)
5	TXD for Mars 600 or TTL RS232 (Green)
6	Not Used (Blue)
7	Not Used (Gray)
8	Not Used (Pink)
9	Not Used (White)
10	Out of Service line (pulled low) (Tan)
11	+12 VDC Power (Red)
12	-Acceptor Enable (Pull low to enable) (Violet)
13	330 Ohm resistor to +5 VDC for LED (White/Orange)
14	-Send line for Mars 600 (White/Blue)
15	Not Used (White/Yellow)
16	RXD for TTL RS232 (White/Red)
17	Not Used (White/Green)
18	Not Used (White/Gray)

**PYRAMID PINOUT**

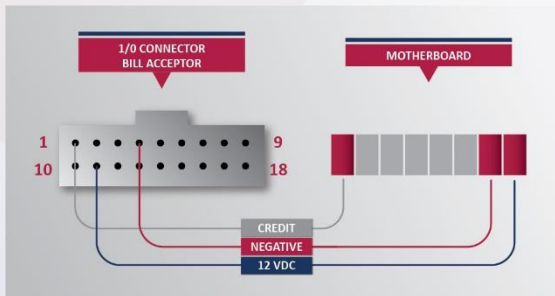
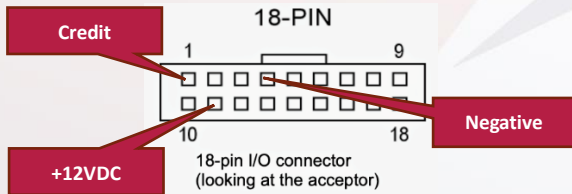

**CONNECTIONS**



# 10. All Available Settings

Refer to page number 5 "MOTHERBOARD CONNECTIONS".

# 11. Maintenance

## BI-WEEKLY CHECKS:

- Air Pressure of Punchball and kicker ball: Ensure correct pressure for optimal operation.
- Punchball Rotation: The punchball must not rotate about its axis.
- Arm Protector: Verify it's correctly placed.
- Motherboard Connections: Inspect for any loose or disconnected wires.
- Machine Level and Balance: Essential for accurate and safety gameplay.
- Warning Stickers: Must be visible and legible.

## MONTHLY CHECKS:

- Mounting Cover Screws and Nuts: Secure all hardware.
- Mechanism Lubrication: Use WD-40 or suitable grease for moving parts.
- Display Lights: Ensure they are functioning properly.
- Cleaning: Coin, bill acceptor or card reader require regular cleaning for reliability.

## ADDITIONAL MAINTENANCE TIPS:

**MECHANISM AND REGULATING SPRING:** All moving parts should be lubricated regularly to prevent rust and ensure smooth operation.

## PUNCHBALL MANUAL RELEASE PROCEDURE:

For scenarios requiring a manual release of the punchball, follow these steps carefully to ensure a safe and effective process:

### 1. Locate the Mechanical Hammer:

- Reach over the punchball to find the mechanical hammer. This component is responsible for holding the punching arm securely in position.

### 2. Identify the Hammer Position:

- Look for a protruding part or lever, typically situated at the top of the machine where the punching arm is mounted. This is often shielded in a way to prevent accidental release.

### 3. Compress the Hammer:

- The hammer is kept under tension by a compression spring. Using your thumb, carefully press down on the hammer. Apply sufficient pressure to compress the spring, which is providing the resistance.

### 4. Release the Punchball:

- Once the hammer is compressed and moved out of the locking position, the punchball arm should now be free. The bag will come down, releasing the tension in the whole system.

## REPLACEMENT OF PUNCHBALL:

### Preparatory Steps:

**1. Lower the Punchball:** Put the arm in a play-mode position, mimicking the position it would be in if ready to be punched.

**2. Remove Front Protection cover.**

**3. Unscrew the Top Nut:**

- Use a 19 mm wrench, preferably with a ratchet, to unscrew the top nut that secures the bag assembly. This will eventually free the punchball.

#### **4. Addressing Excessive Movement:**

- If the punchball is noted for excessive vibration or rotation, first loosen the lower nut before tightening the top nut. Make these adjustments until there is no perceptible rotation of the bag around its axis.

#### **5. Installation of New Punchball:**

- Ensure the tension nut is completely removed, and the second nut is wound down close to the end of the bolt. Failing to do so can obstruct the proper tightening of the punchball later on.

#### **6. Place the New Punchball:**

- Slot the new punchball onto the designated bolt/arm. This should be straightforward if the prior steps are completed correctly.

#### **7. Replace and Tighten the Tension Nut:**

- Reattach the tension nut on the bolt, tightening it until the punchball is secure. To test, hold the bag and gently use your body weight to twist it. The bag should not rotate or move excessively on its axis.

#### **8. Finishing Touches:**

- Unscrew the secondary nut until it presses firmly against the metal arm, securing everything in place.

#### **9. Final Testing:**

- Once assembled, manually test by striking the punchball gently to observe stability and response. Ensure there are no unusual movements like excessive wobbling or spinning.

#### **10. Operational Test:**

- Turn on the machine and run a few test games to ensure the newly installed punchball functions as expected during normal game play.

### **REPLACEMENT OF PUNCHBALL BLADDER:**

- 1. Preparation:** Ensure that the machine is turned off and that you are wearing appropriate safety gear.
- 2. Access the Bladder:** You need to lower the bag arm into a position where it is safe and easy to work with.
- 3. Untie the Rope:** Locate and untie the rope or laces that secure the punchball cover. This might require some patience as the knots can be tight and stiff.
- 4. Remove the Leather Cover:** Carefully open and peel back the leather of the punchball to expose the bladder inside.
- 5. Take Out the Old Bladder:** Gently remove the old bladder. Be cautious not to tear or damage the cover as it will be reused.
- 6. Installing the New Bladder:** Before installing, check the new rubber bladder for any defects or irregularities. Ensure it's the correct size and type for your specific punchball model.
- 7. Position the Valve:** Position the bladder so that the valve aligns precisely with the hole designated for it on the punchball cover. This is crucial as it ensures the bladder can be inflated properly without bending or stressing the valve.
- 8. Insert the New Bladder:** Carefully tuck the new bladder inside the cover. Make sure it is evenly placed without any twists or folds that could affect the ball's shape and bounce.
- 9. Securing the Bladder:** Once the bladder is correctly positioned, carefully pull, and secure the cover back over it. Ensure the valve remains accessible through the cover's hole.
- 10. Tie the Rope:** Securely retie the rope or laces to ensure that the cover holds the bladder snugly.
- 11. Inflate the Bladder:** Using an air pump, inflate the bladder through the valve. Check for the recommended pressure level specific to your punchball to ensure optimal performance.
- 12. Functional Test:** Once inflated and secured, perform a few manual punches to ensure the punchball feels firm and rebounds correctly.

### **MAIN SWITCH FUSE REPLACEMENT:**

- 1. Safety Precautions:** Ensure the machine is completely powered off.
- 2. Locate the Fuse Holder:** Check the back of the machine where the power cord connection is located. The fuse holder is typically positioned between the power cord socket and the main ON/OFF switch. It might be concealed, so look for a small compartment or panel.

- 3. Open the Fuse Holder:** Using a flat screwdriver, gently pry open the fuse holder. These holders can sometimes be tight or may have a small notch for insertion of the screwdriver. Apply sufficient pressure but be careful not to damage surrounding areas.
- 4. Remove the Old Fuse:** Pull out the fuse from the holder. Most fuses will easily come free with a gentle tug. If the fuse is stubborn, ensure that you're not applying excessive force which could break the holder.
- 5. Installing the New Fuse:** Before installing a new fuse, check the specifications of the old fuse, including the type and amperage, which are usually printed on the end caps or the body of the fuse. Ensure the new fuse matches these specifications exactly to prevent damage to the machine.
- 6. Insert the New Fuse:** Place the new fuse into the holder. Make sure it fits snugly and is not loose. Some fuse holders might snap shut, while others might need a gentle push to secure the fuse in place.
- 7. Close the Fuse Holder:** Ensure the fuse holder is firmly closed and secured. Depending on the design, you might hear a click or just need to check if it's firmly in place.
- 8. Reconnect the Power:** Plug the machine back into its power source.
- 9. Power On the Machine:** Turn on the machine using the main ON/OFF switch. Observe the initial response of the machine; there should not be any sparks, smoke, or unusual noises.
- 10. Operational Test:** Conduct a basic operational test to ensure that the machine is functioning as expected without tripping off or failing to power up.

## 12. Troubleshooting

### MOTHERBOARD IS NOT FUNCTIONING

- **Inspect Power Cable:** Check the condition of the power cable for any visible damage or wear.
- **Check Power Supply Connection:** Ensure that the power cable is firmly connected to both the mainboard and the power source.
- **Check All Fuses:** Inspect all fuses for continuity using a multimeter. Replace any blown fuses.

### NO SOUND

- **Volume Potentiometer:** Adjust the volume control on the motherboard to check functionality.
- **Speaker Connections:** Verify that the speakers are correctly connected to the motherboard.
- **Inspect Speaker:** Check for any damage or faults in the speaker itself.
- **Motherboard Connector:** Verify that it is properly connected.

### DISPLAY IS NOT FUNCTIONING

- **Check Connections:** Ensure the display cables between the display and the motherboard are secure and undamaged.

### COIN OR BILL ACCEPTOR ARE NOT FUNCTIONING

- **Check for Jams:** Look for and remove any obstructions or jammed coins/bills.
- **Clean Acceptors:** Remove any dust or debris that might be interfering with the mechanisms.
- **Inspect Connections:** Make sure the connector wires between the acceptor units and the motherboard are intact and properly connected.

### BUTTON START IS NOT FUNCTIONING

- **Connection Check:** Ensure that the button is correctly connected to the motherboard.
- **Button Switch:** Examine the button switch for any signs of damage or failure.

## NO LIGHTING (LEDS, HALOGENS)

- **Check Fuses on Main Board:** Reconfirm that all fuses related to lighting are intact.
- **Inspect Bulbs:** Replace any faulty bulbs.
- **Motherboard Connectors:** Make sure are properly connected.

## MECHANISM PUNCHBALL NOT RELEASE

- **Manual Unblock:** If the mechanism is caught on the edge, manually unlock it and smooth the edge to prevent future occurrences.
- **Electromagnet Function:** Listen for the distinctive “clack-clack” noise when the start button is pressed, signaling proper electromagnet function.
- **Optical Sensor Checks:** Confirm that the optical sensor's connection to the mainboard is secure and positioned correctly.

## PUNCHBAG IS NOT LOCKING

- **Spring Tension:** Check if the spring is properly extended. Adjust using the nut on the end of the spring for correct positioning.

## PUNCHBAG STOPS HALFWAY OR CLOSSES IMMEDIATELY AFTER OPENING

- **Spring Adjustment:** Similar to the above, ensure the spring is adequately stretched and adjust using the nut to achieve the proper position.

# 13. Warranty and Service

**Warranty Provider:** PRO-GAMES POLAND / UPLAY AMERICA, LLC.

**Coverage:** Free replacement of damaged spare parts as per warranty certificate.

**Warranty Period:** 1 year from the date of sale.

**Customer's Responsibility:** Cost for shipping the parts.

**Ownership:** Replaced parts become the property of Pro-Games Poland/Uplay America, LLC.

**Components under warranty:**

- Motherboard.
- Displays.
- Boxer/kicker mechanism.
- Bill acceptor.
- Cables.
- Electromagnet/Solenoid.
- Any damages caused during the production process.

The warranty does not cover mechanical damages caused by inappropriate use, service, operation, disasters, or any random events. Normal wear and tear on spare parts such as light bulbs, bladder, punchballs, kicker balls, and bumpers is not covered by this warranty. The warranty also does not include the customer's right to demand repayment for estimated profits lost due to damage.

Utilizing this troubleshooting guide can notably reduce downtime and ensure smooth operations, enhancing the overall sustainability and appeal of arcade gaming equipment. For any repairs or replacements under warranty, ensure you retain the warranty certificate and provide a detailed description of the issue to benefit from the covered services properly.



# WARRANTY

CERTIFICATE

Model of device: \_\_\_\_\_

Serial number: \_\_\_\_\_

Motherboard number: \_\_\_\_\_

Customer name: \_\_\_\_\_

Invoice no.: \_\_\_\_\_

Sale date: \_\_\_\_\_

Stamp of Pro-Games Poland / Uplay America:

\_\_\_\_\_

DATE

\_\_\_\_\_

STAMP